

PDQ STANDARDS

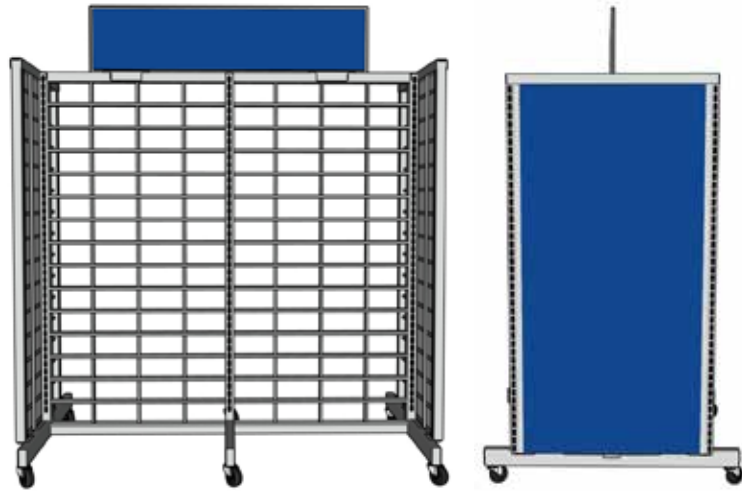

APPROVED RACETRACK FIXTURES

Below outlines the approved racetrack fixtures for Academy Sports + Outdoors. Any exception to the below needs Vice President Visual Merchandise Presentation approval.



24" x 48" x 58" RACETRACK GRID

A single racetrack grid can also occupy one Racetrack position.



48" x 40" x 58" PDQ DISPLAY

A full size 48" x 40" x 58" max freestanding floor PDQ Display



24" x 48" x 58" PDQ DISPLAY

A half size 48" x 24" x 58" max freestanding floor PDQ display. In all cases another freestanding floor PDQ will be paired together to create one position in the Racetrack. The paired PDQ must correspond to the matching PDQ on the opposite side.



48" x 40" x 50" FLOOR STACK

A full size 48" x 40" x 50" max bulk item display.



24" x 24" x 33" DUMP BIN

A 24" x 24" wire basket dump bin. Two placed side to side.



48" x 40" x 36" DUMP BIN

A 48" x 40" wire basket dump bin.

ALL PDQ'S MUST BE PRE-APPROVED & MAINTAIN STANDARD GUIDELINES BEFORE PROCEEDING FOR PRODUCTION. PLEASE ALLOW 3-6 MONTHS FOR REVIEW TO ACCOMMODATE PRODUCTION SCHEDULE AND MEET IN-STORE DELIVERY DATE.

OBJECTIVE

In support of Academy Sports + Outdoors key seasonal business and strategic sales opportunity within our racetrack configuration

PDQ's are geared to be instrumental selling fixture.

The objective of the PDQ Display is to move merchandise from the receiving dock to the sales floor or shelf in the most efficient, timely and cost effective manner, freeing store team members to focus their efforts on the customer.

PDQ DISPLAY - DEFINITION

The Store Ready Display (PDQ) is a corrugate displayer (pallet or tray) used to hold multiple pieces of merchandise for quick stocking and restocking of the sales floor. It also contains a space for marketing product information and pricing to help the customer understand the value of the product.

ARRIVE AT STORE



Shelf Tray

STOCK ROOM



ON SALES FLOOR



PDQ



RULE 1 - DELIVER THE MESSAGE

DELIVER THE MESSAGE ON A PDQ DISPLAY

1. Academy Sports + Outdoors Price is clearly displayed
2. Show the Value of product (always to the left of the PDQ)
3. Functional Retail Design

Messages featured on PDQ Displays must be tailored to delivering a great in-store shopping experience by meeting customers' needs. They must be written within the context of a retail environment to effectively engage customers through education, inspiration or demonstration.

Messages must address a customer need, be engaging, and complement Academy Sports + Outdoors tone and voice.



RULE 2 - PDQ DISPLAY INTEGRITY

DESIGN

A PDQ Display must be designed with a balance of materials to maintain structural integrity for product size and weight.

- Keep PDQ Display design within specifications.
- Always think of customer and team member safety.
- PDQ Display must withstand customer shopping without damage.
- **Structural sample must be delivered to the corporate office and allow 3 months for final approval before mass production begins.**

CORRUGATED BOARD GRADE

- Corrugated PDQ Displays are required to be produced from ECT32 board or stronger.
- They must never be built with a weaker material for use in Academy Sports + Outdoor Stores.
- Larger and heavier products may require heavier grades.
- Proper design and testing should be done with the actual product merchandised within the display to ensure that the proper the grade is selected.

MINIMUM MATERIAL SPECIFICATIONS

- Light to medium weight merchandise = 175# Mullen (Burst) "B" Flute
- Medium to heavier weight merchandise = 200# Mullen (Burst) "B" Flute

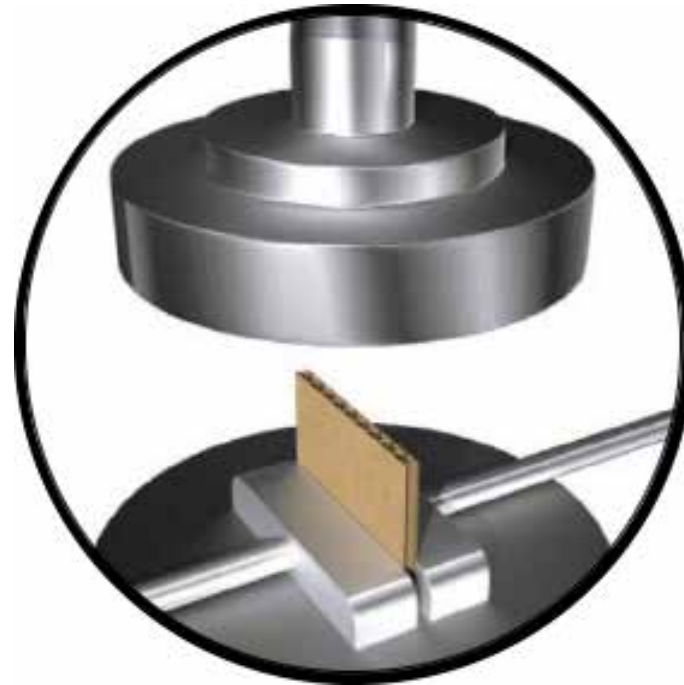

EDGE CRUSH TEST (ECT)

Corrugated-board test to determine the force that will crush a standard size of board standing on an edge. ECT indicates the probable compression strength of the container made from the board.



MULLEN (BURST) TEST

Corrugated-board test to measure the pressure required to puncture a sheet of corrugated-board as an indicator of its load carrying capacity under specific conditions.

FLUTE

Inverted S-shaped 'arch' or 'wave' of a corrugated medium that normally runs parallel to the depth of the container and gives it rigidity and crushing (stacking) strength.

COMMON FLUTE SIZES

C-FLUTE
11/64"



B-FLUTE
1/8"



A-FLUTE
1/4"



RULE 3 - PRICE SIGN DISPLAY

DELIVER THE MESSAGE ON A PDQ DISPLAY

- 11" x 8.5" Pricepoints (pricepoint printed in-store)
- All pallet displays must include a built-in, effective method for holding a top-load 11" x 8.5" pricepoint sign. Vendors or Suppliers are responsible for supplying a complete Pallet Display that would include a means of securing a 11" x 8.5" pricepoint. The pricepoint should ALWAYS be placed left justified.

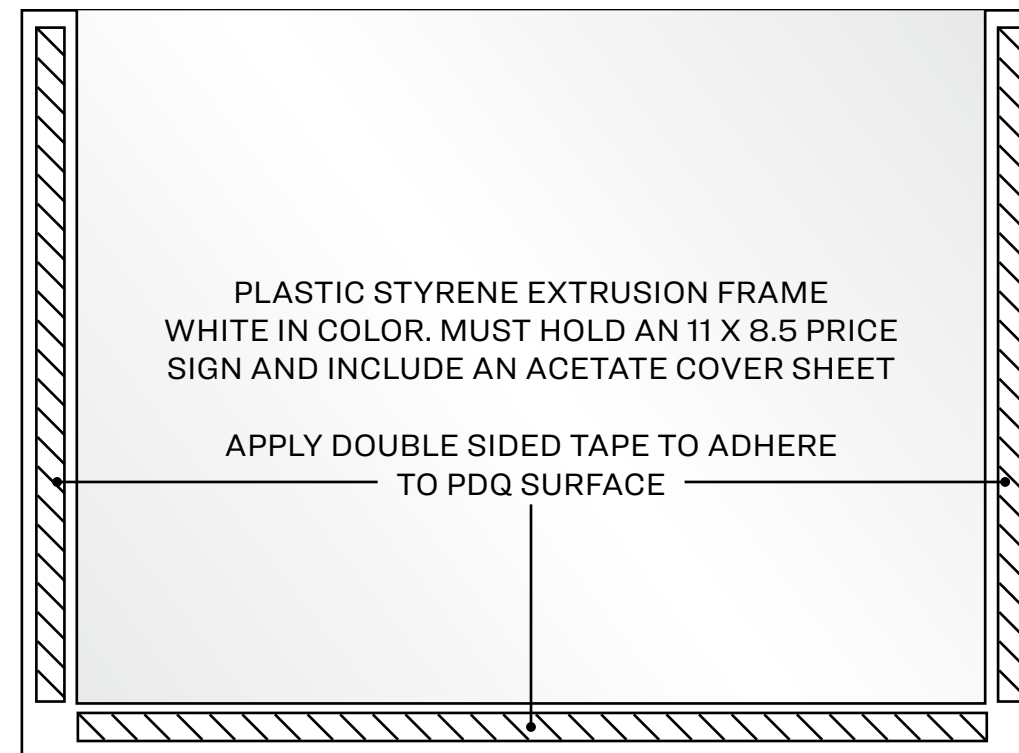
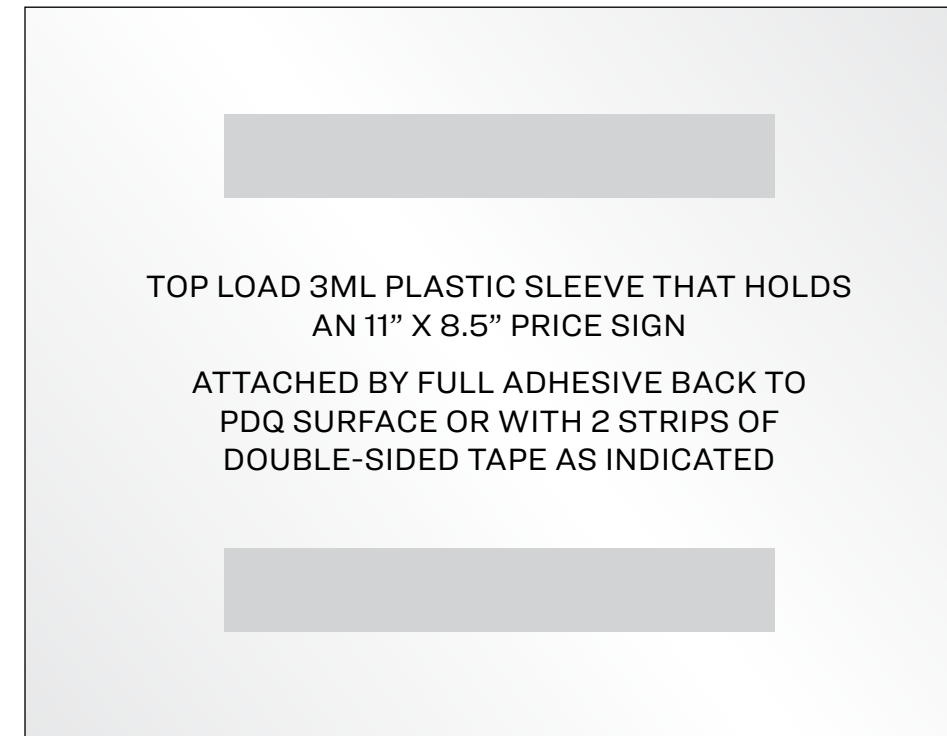

INTRODUCTION

PALLET DISPLAY DEFINITION

Pallet Displays are cost effective vehicles used to promote products and quickly merchandise a larger volume of product in the racetrack and specialty locations around the store. Pallet displays ship to stores fully assembled and fully stocked.

- Must include a 9" header for branding and marketing, and must also include a top-load pricing pouch to hold an 11" x 8.5" Price Sign (always to the left of the PDQ)
- Quarter pallets and floor-stand displays are NOT acceptable display formats in Academy Sports + Outdoors stores.

PALLET DISPLAY - IN-STORE EXECUTION

- Displays must provide adequate protection during shipping and at store level.
- Store labor must be reduced to a minimum.
- Pallet displays must NOT be stapled or glued to pallets. It's recommended to shrink wrap the contents to the pallet for shipping.
- Pallet displays must be designed for efficient use of space and materials.
- Reinforce top of PDQ and strap to pallet to protect in shipping.
- Pallet displays will generally merchandise products using a combination of the following styles:

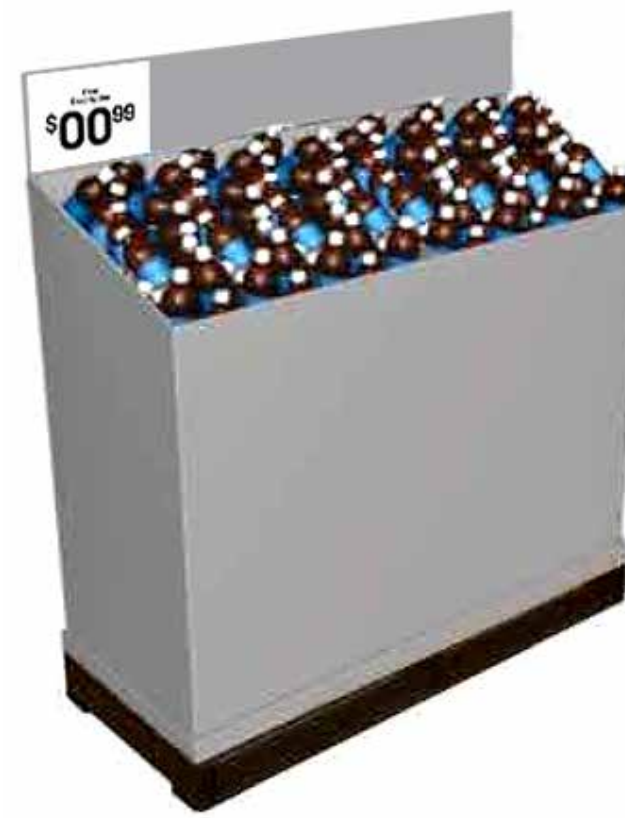
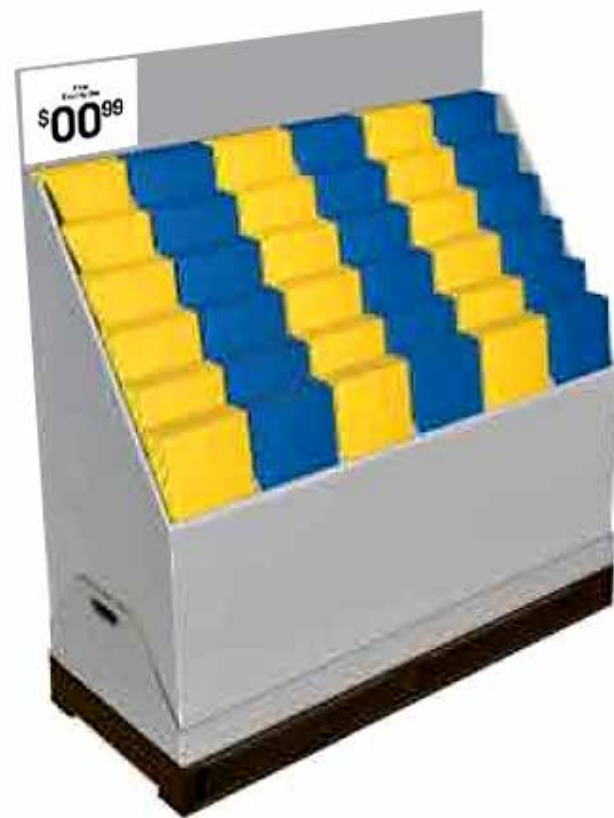

RACETRACK LINE-OF-SIGHT

When looking down The Racetrack, each pallet display must be the same height in order to create a clean line-of-sight. By having a consistent line-of-sight the stores will have a cleaner, more organized appearance and consistent Academy Sports + Outdoors pricing and brand message.

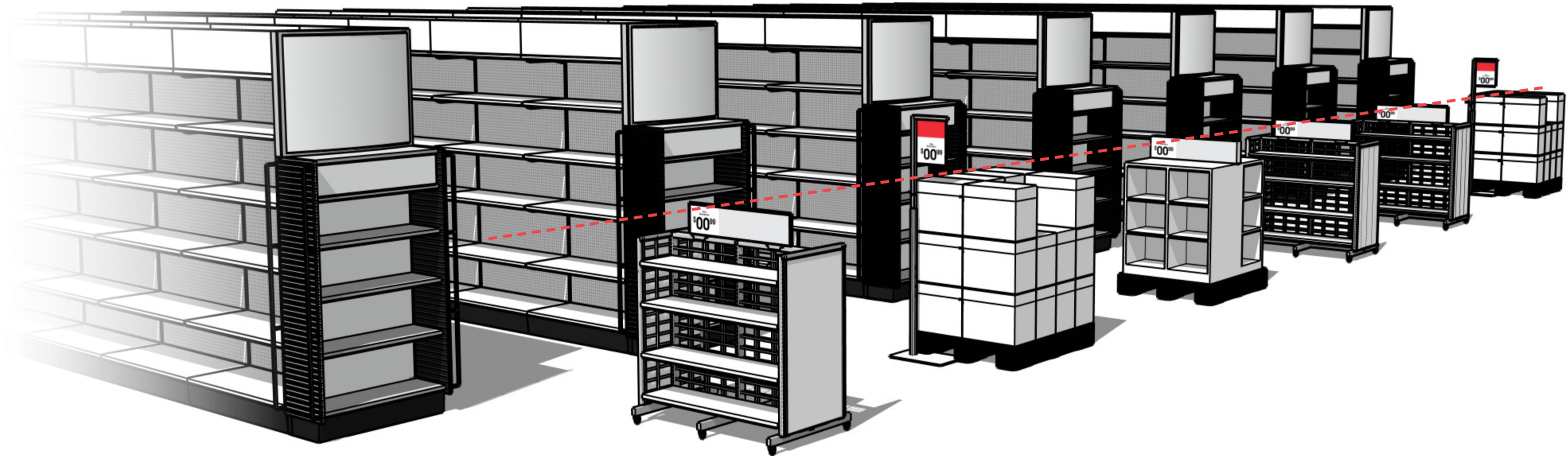

HALF PALLET

VOLUME

Must maximize the volume of space allocated. For example, a 40" x 48" pallet must be filled from pallet base to height of the display unit. Do not exceed 15% air space in the center of the display unit.

FALSE BOTTOMS

A False bottom is an air cavity that lifts the product higher above the floor level. This type of unit does not maximize the selling space available. Displays with a 50% or larger air space are NOT acceptable. Some dump bin pallet displays may require a larger false bottom.

FOOTPRINT

Must fill the pallet foot print. For example, a 40" x 48" display pallet must fill this footprint to within 1" around the perimeter edge of the pallet, i.e. 38"x 46" minimum fill space. **Under-hang must NOT exceed 1"**

If a display fills the entire footprint of the pallet, the total shroud height must be the exact height from floor to the top of the display. An incorrect height can cause the display to carry an excessive load, or leave air space in the shroud causing premature collapse and a weak shipping scenario.

Limit Air Space to 15%



No 50% or more false bottom displays

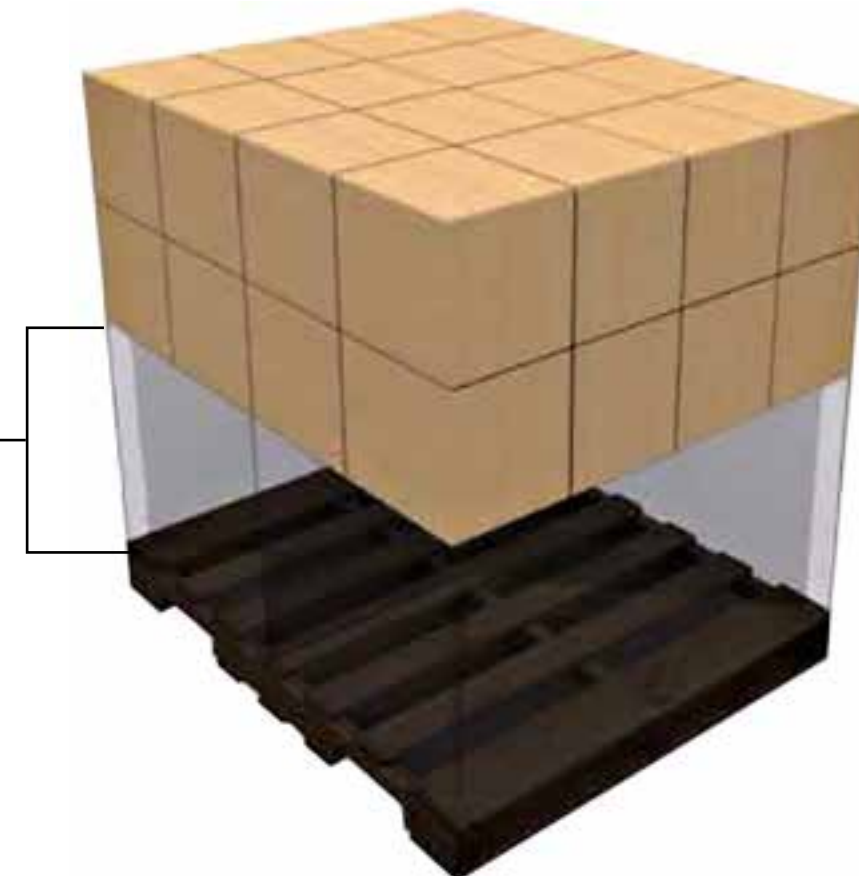

HALF PALLETS

- 24" x 48"
- 59" Maximum Height (including 9" header and 5" pallet)

SHOPPABLE FACINGS

- 1 Side Shoppable (Preferred)
- 3 Side Shoppable
- The backside of the facing side must not be shoppable. This allows the half pallet display to back up to another half pallet display.
- Pricing -One Price Per Half Pallet (single pricepoint)
- Two half pallets that sit back to back must be attached using plastic fasteners, they CANNOT use glue or tape.

TOP VIEW



- 1 Side Shoppable (preferred)
- 1 Academy Price

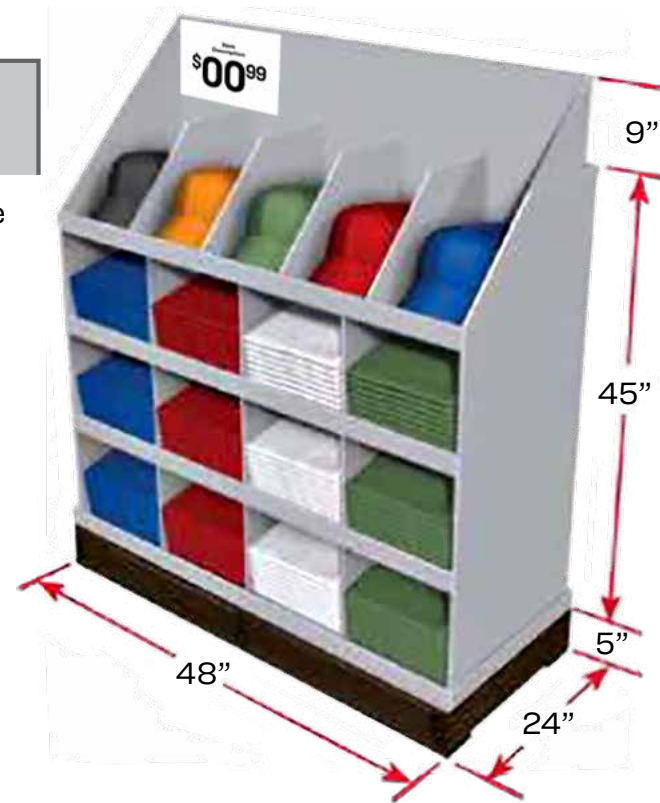

TOP VIEW

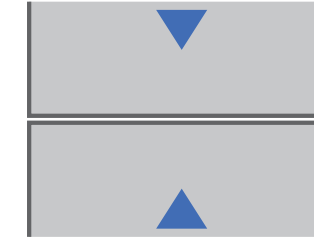

- 1 Side Shoppable
- 2 Half Pallets Back to Back
- 1 Academy Price (Per Half Pallet)

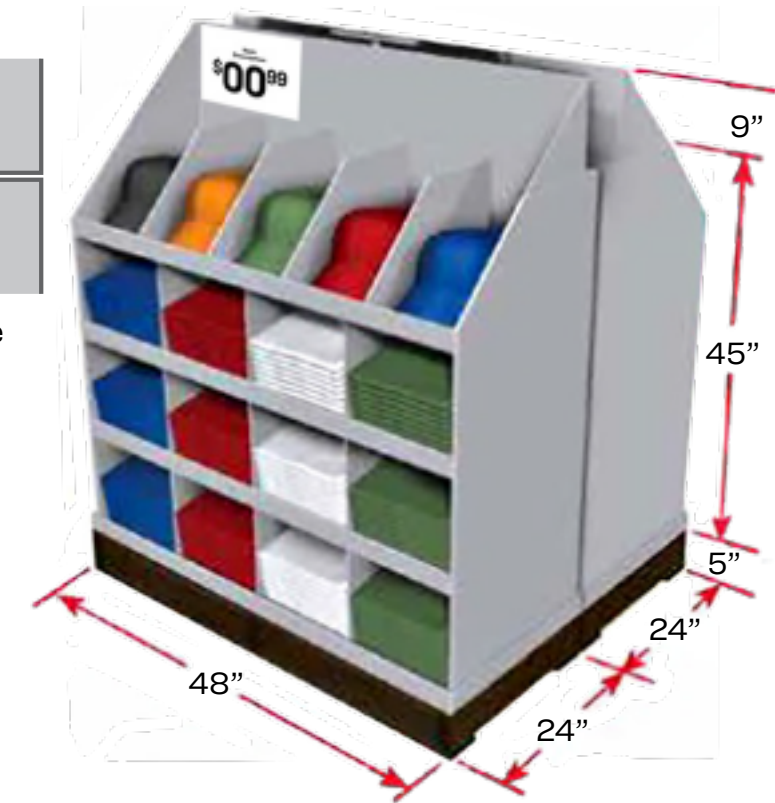

TOP VIEW



- 3 Side Shoppable
- 1 Academy Price

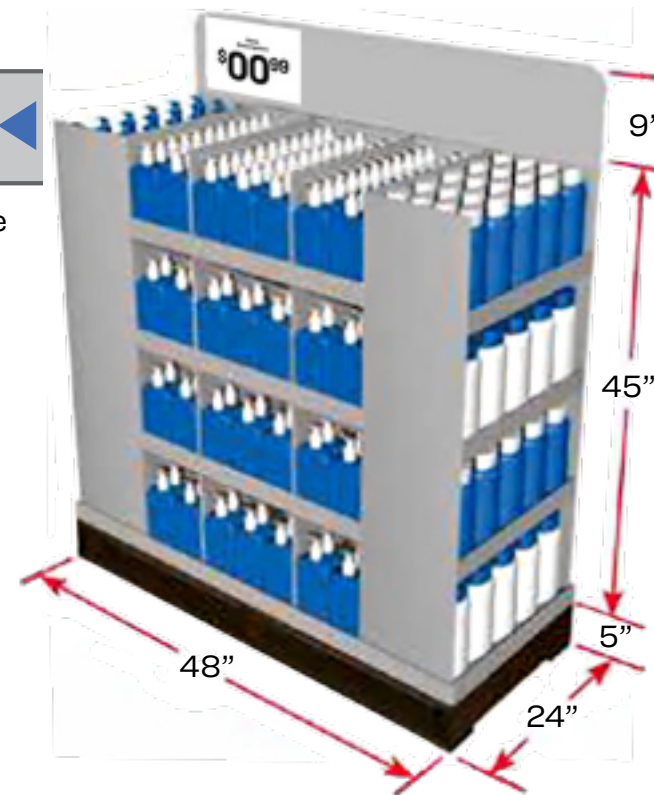

TOP VIEW

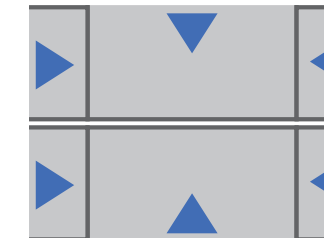

- 2 Half Pallets Back to Back
- 1 Academy Price (Per Half Pallet)

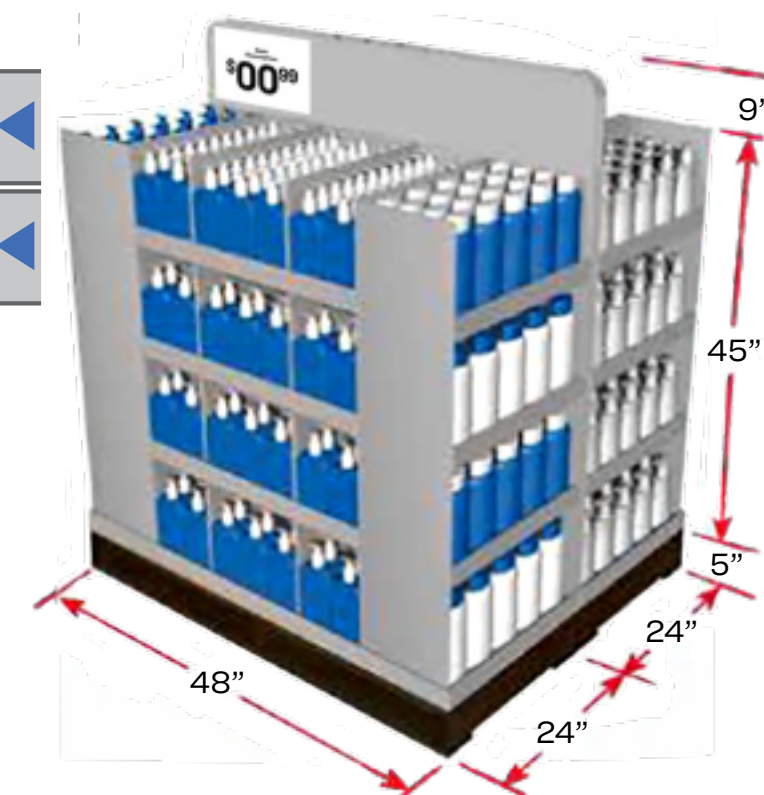

FULL PALLETS

- 40" x 48"
- 59" Maximum Height (including 9" header and 5" pallet)

SHOPPABLE FACINGS

- 2 Side Shoppable (Preferred)
- 4 Side Shoppable

PRICING (ONE PRICE PER PALLET)

- Academy Sports + Outdoors in its sole discretion determines its retail prices of products in pallet displays.
- An 11" x 8.5" pricepoint sign must be used on all pallet displays to display the Academy Sports + Outdoors price point. The pricepoint should ALWAYS be placed left justified.
- A full pallet display must hold product with 1 Academy Sports + Outdoors pricepoint.
- A half pallet display must hold product with 1 Academy Sports + Outdoors pricepoint.

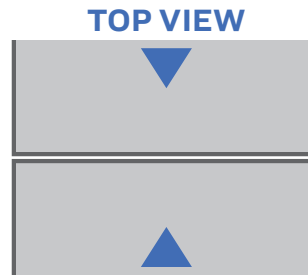

- 2 Side Shoppable (Preferred)
- 1 Academy Price (Entire pallet)
- 2 Academy Prices (Front Side & Back Side)

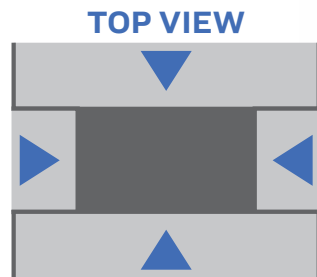
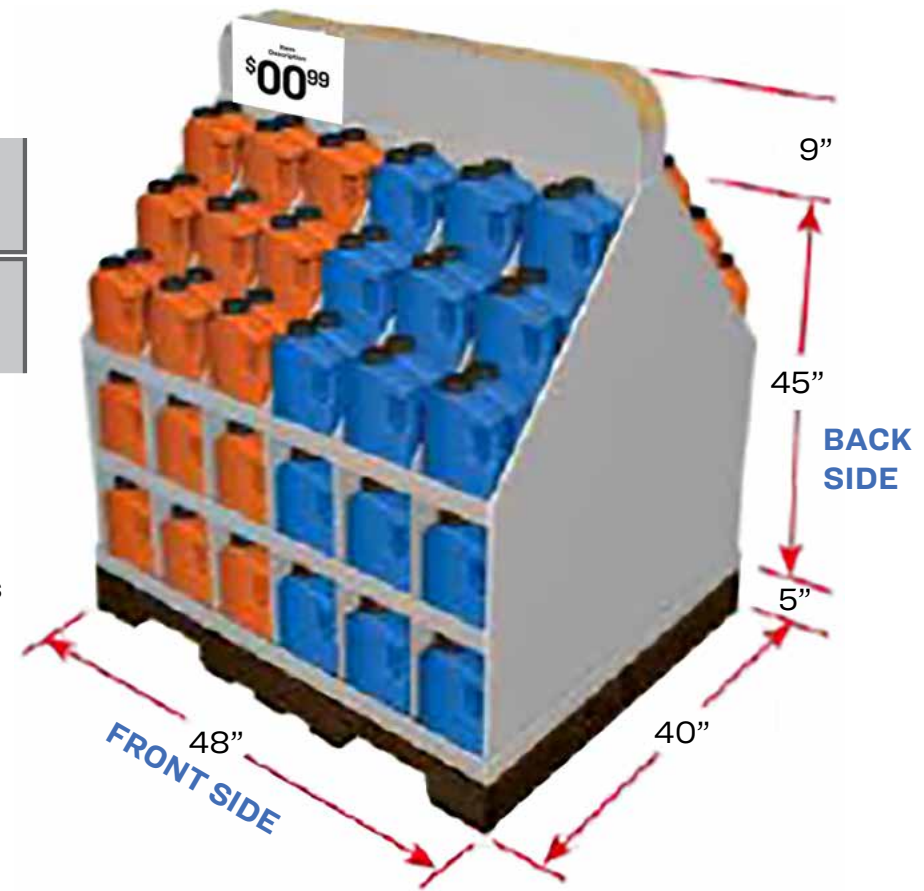

- 4 side Shoppable (Not Divided)
- 1 Academy Price (Entire Pallet)

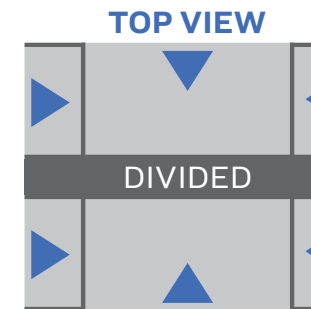
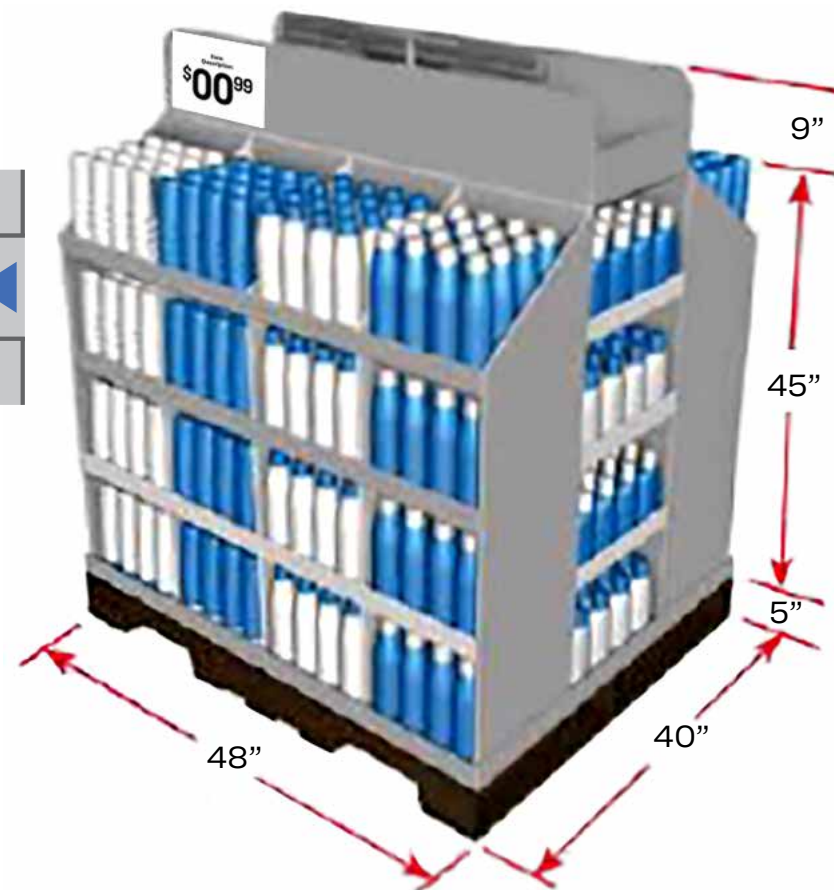

- 4 side Shoppable (Divided)
- Academy Price (Entire Pallet)

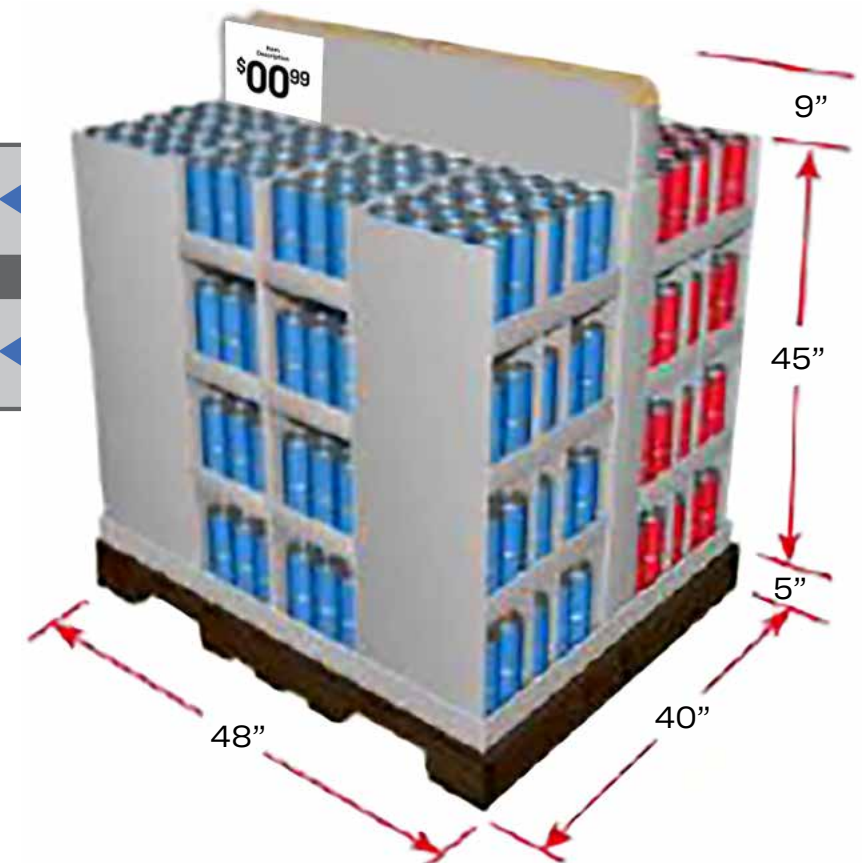

DUMP BINS

FULL PALLET SIZES

- 40" x 48"
- 59" Maximum Height (including 9" header and 5" pallet)

HALF PALLET SIZES

- 24" x 48"
- 59" Maximum Height (including 9" header and 5" pallet)

SHOPPABLE FACINGS

- 2 Side Shoppable (Preferred)
- 4 Side Shoppable

PRICING (ONE PRICE PER PALLET)

- Academy Sports + Outdoors in its sole discretion determines its retail prices of products in pallet displays.
- An 11" x 8.5" pricepoint sign must be used on all pallet displays to display the Academy Sports + Outdoors price point.
- A full pallet display must hold product with 1 Academy Sports + Outdoors pricepoint.
- A half pallet display must hold product with 1 Academy Sports + Outdoors pricepoint.

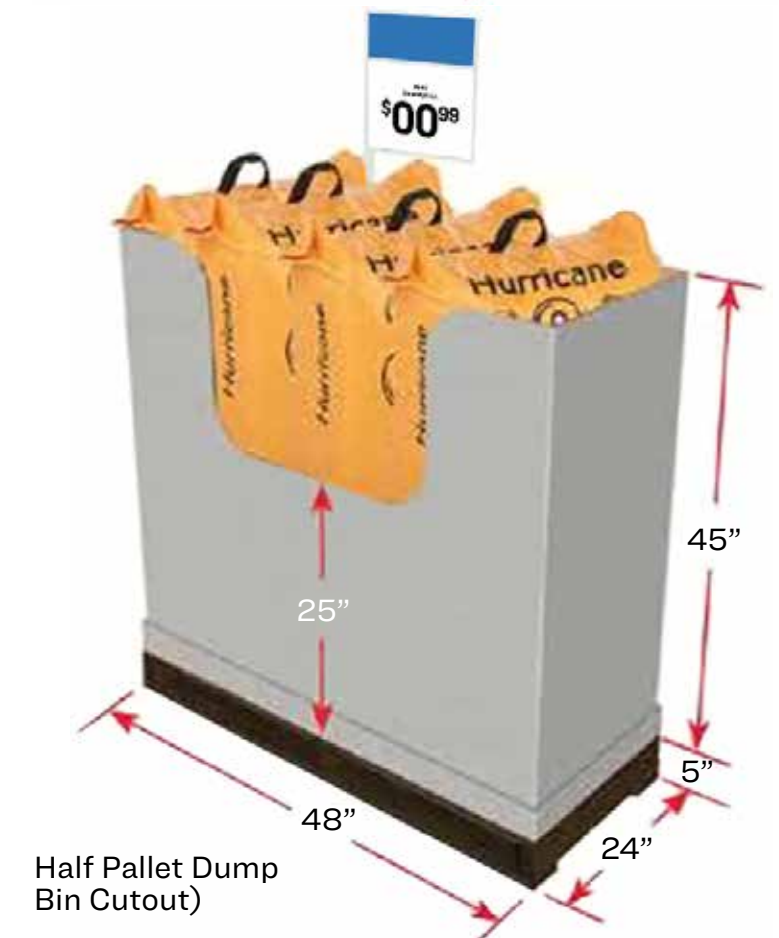
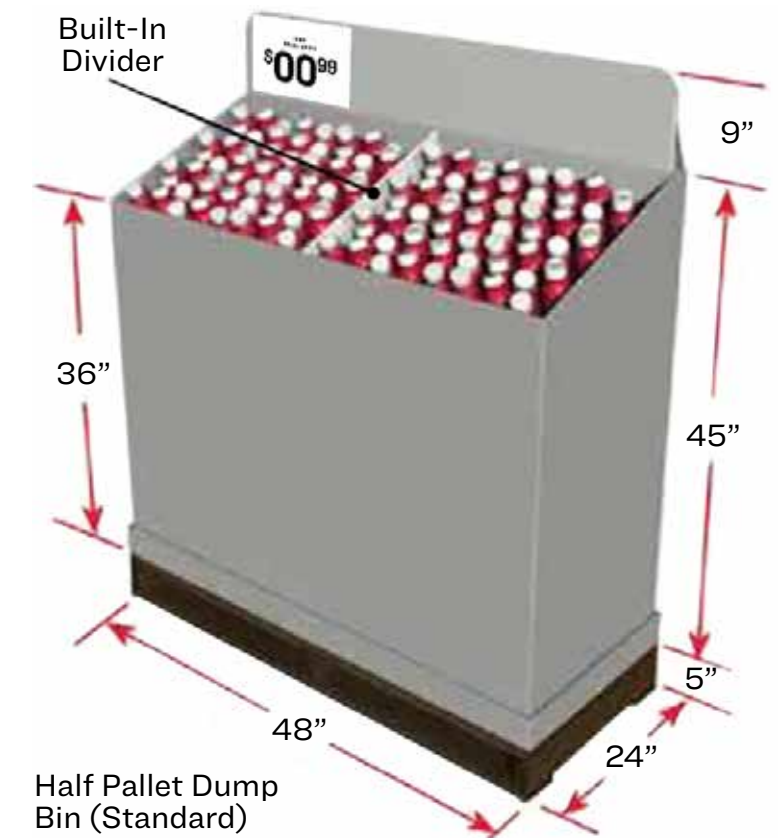
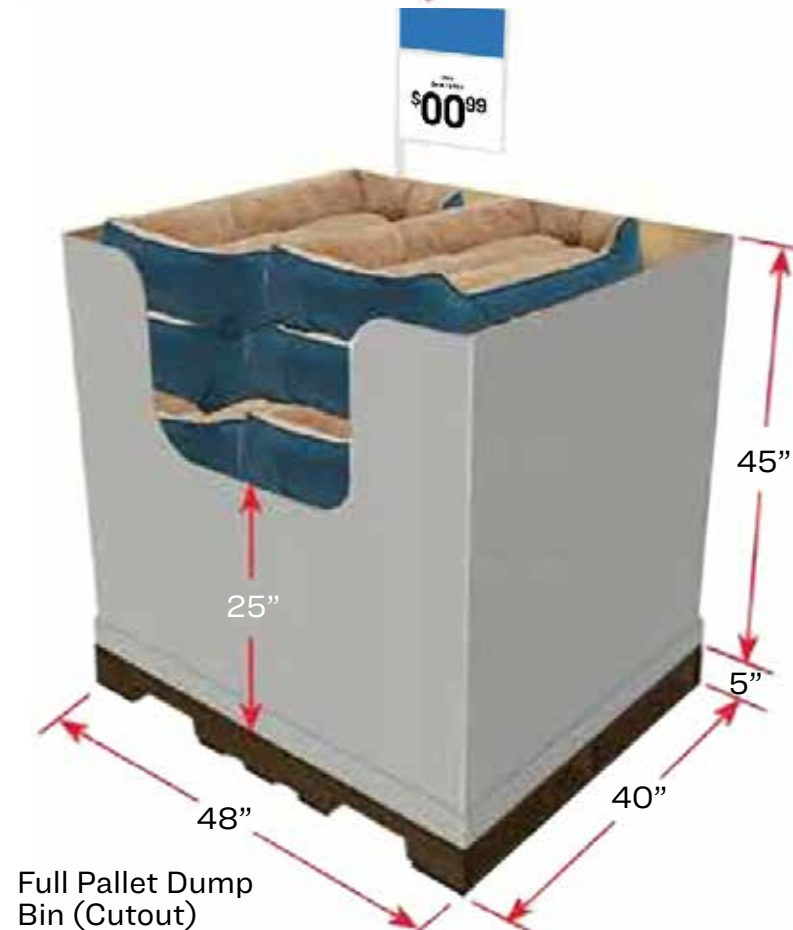
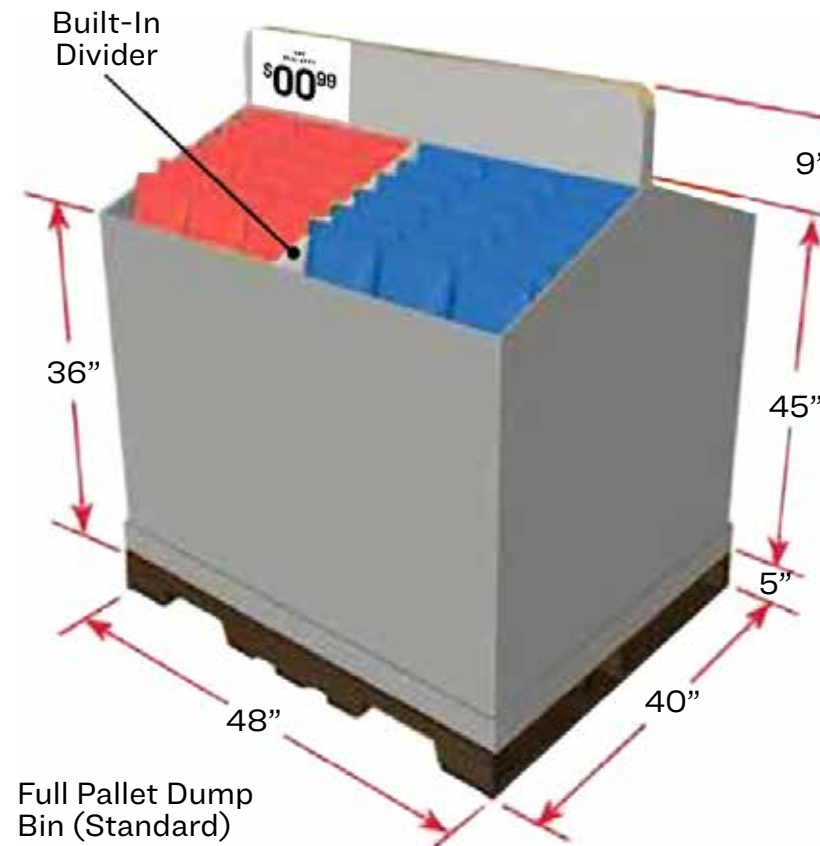

PDQ DISPLAY INTEGRITY & SAFETY

DISPLAY INTEGRITY

- Display strength is determined both by material selection and design integrity. It is essential to design a display with adequate strength to hold up throughout the display life cycle.
- Material strength during sample phases can be drastically reduced by the time the production piece is manufactured due to machine crush, ink application, product load and shipping vibration. Designers must design with safety in mind.

GENERAL DISPLAY & INTEGRITY

- Designers must first explore and test all displays using only corrugated materials. This will ensure that all display materials can be recycled.
- Only use hardware such as plastic clips, brackets, or metal poles when it is determined to be the most effective and safest option.
- Internal hardware components can simplify a structure and increase overall strength.
- Hardware must NOT be placed in a location or manner where a shopper might sustain injury from sharp edges.
- **Structural sample must be delivered to the corporate office and allow 3 months for final approval before mass production begins.**

EXAMPLE ONLY

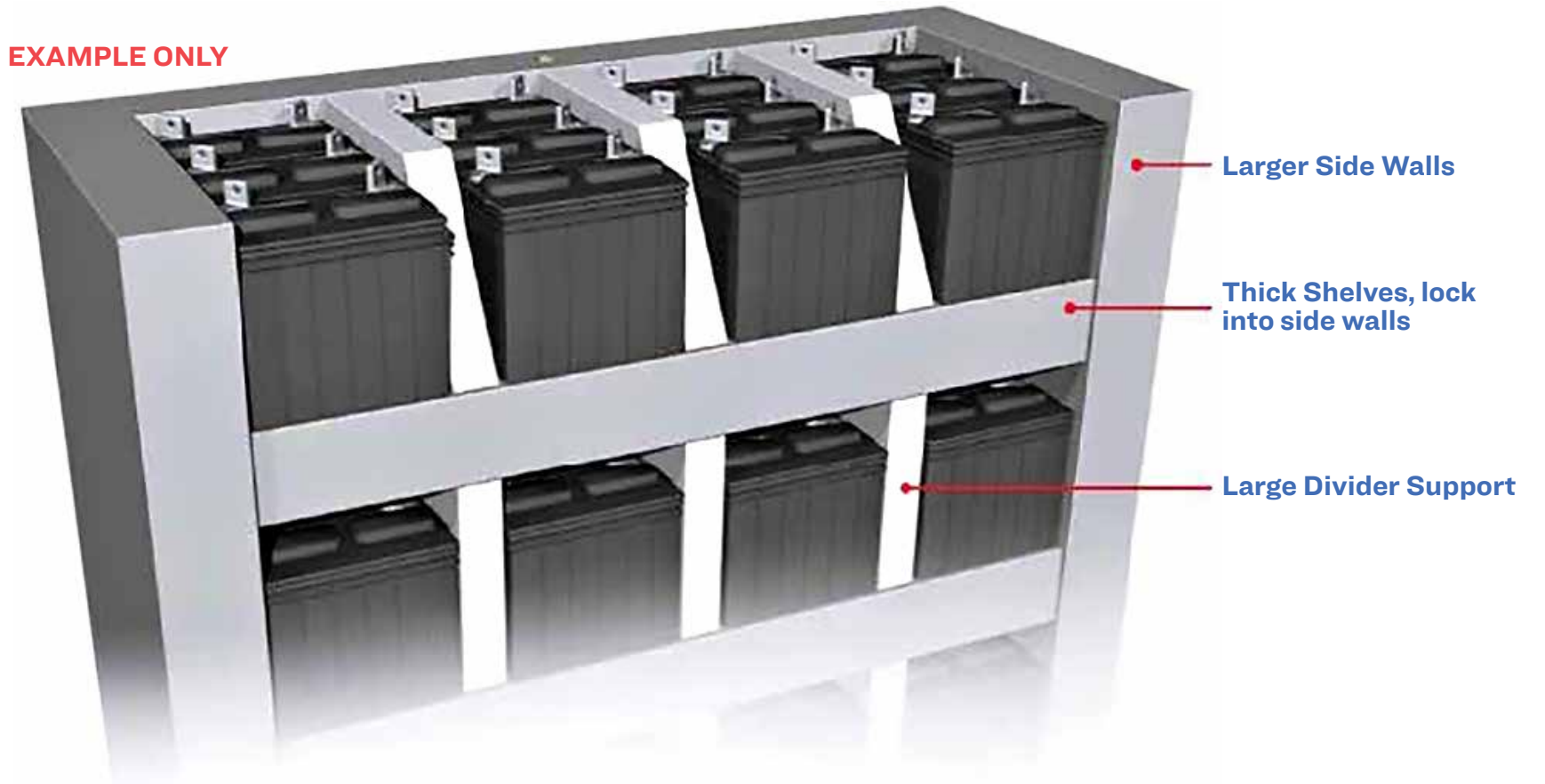

Shelf Support Clip



Shelf Support Locking Clip



Shelf Support Metal Pipe



The above hardware shown can be sourced from siffron.com or kinter.com.

INTRODUCTION & SIZING

SIDEKICK DEFINITION

- A Sidekick is a compact, lightweight display that is designed to be space efficient and easy to set up. They are intended for impulse buying. Sidekicks hang inside a wire frame fixture, Skat Wall fixture or similar located at the end of an aisle.

SIDEKICK SIZES

- 14" Maximum Width
- 3" Maximum Depth
- 24" Height
- 48" Height

MAXIMUM WEIGHTS

- 25 lbs for 24" Sidekick
- 50 lbs for 48" Sidekick

HEADERS & GRAPHIC PANELS

- Headers or graphic panels must be included as part of the sidekick rather than having separate parts that need to be assembled.
- For items not physically in a sidekick PDQ the top 8" - 10" can be used for a branded graphic call out.

INTEGRITY

- Pegged product and shelf style sidekicks must have rolled edges for added strength and overall display presentation.
- Sidekicks with products on plastic hooks must be designed and properly tested before shipping. The display must be fully loaded with merchandise to ensure that the weight of the product will hold up in store.

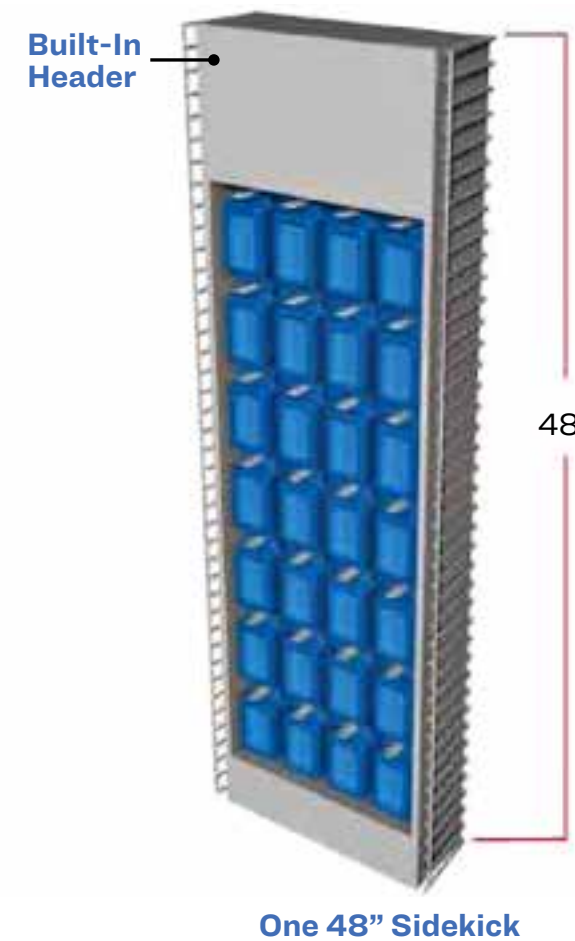
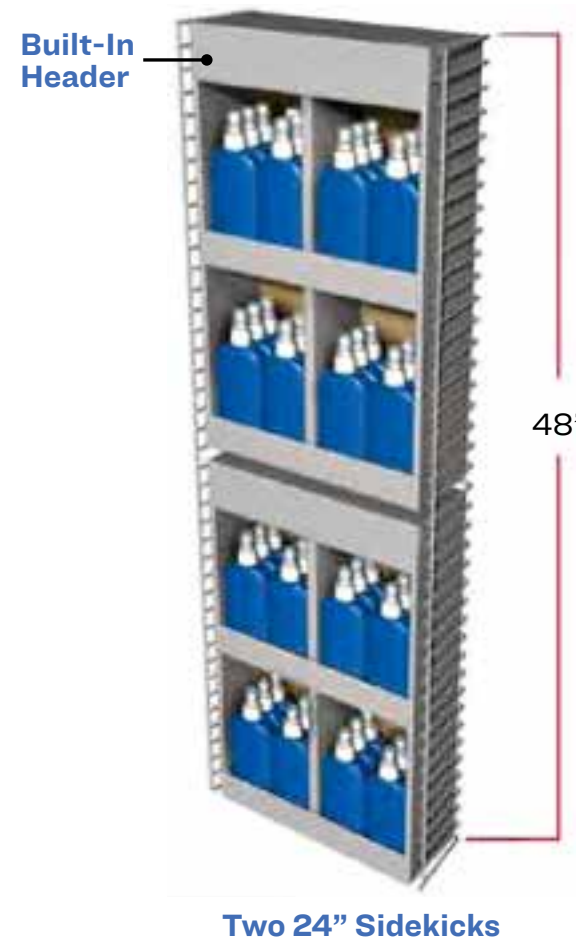
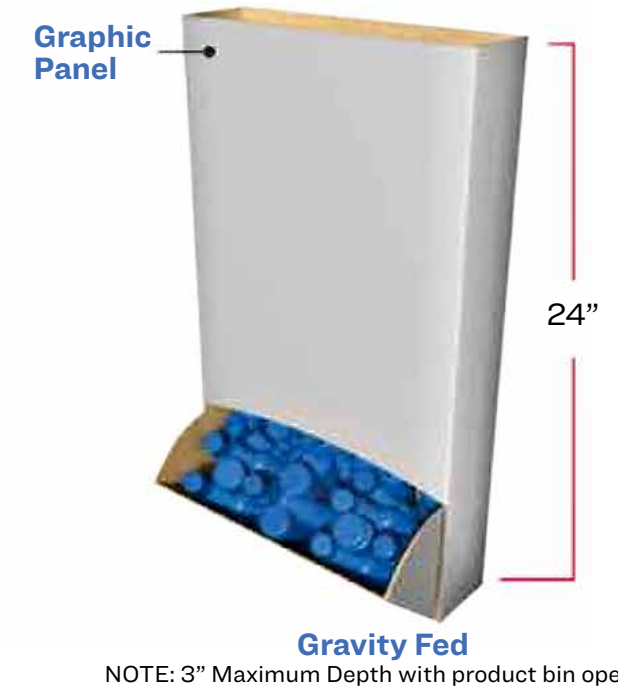

PRICING

SIDEKICK PRICING

- All products in a sidekick display must be one price point.
- Pegged Sidekicks must include a 2" x 1.5" scanner plate for each peg so that they may be properly priced.

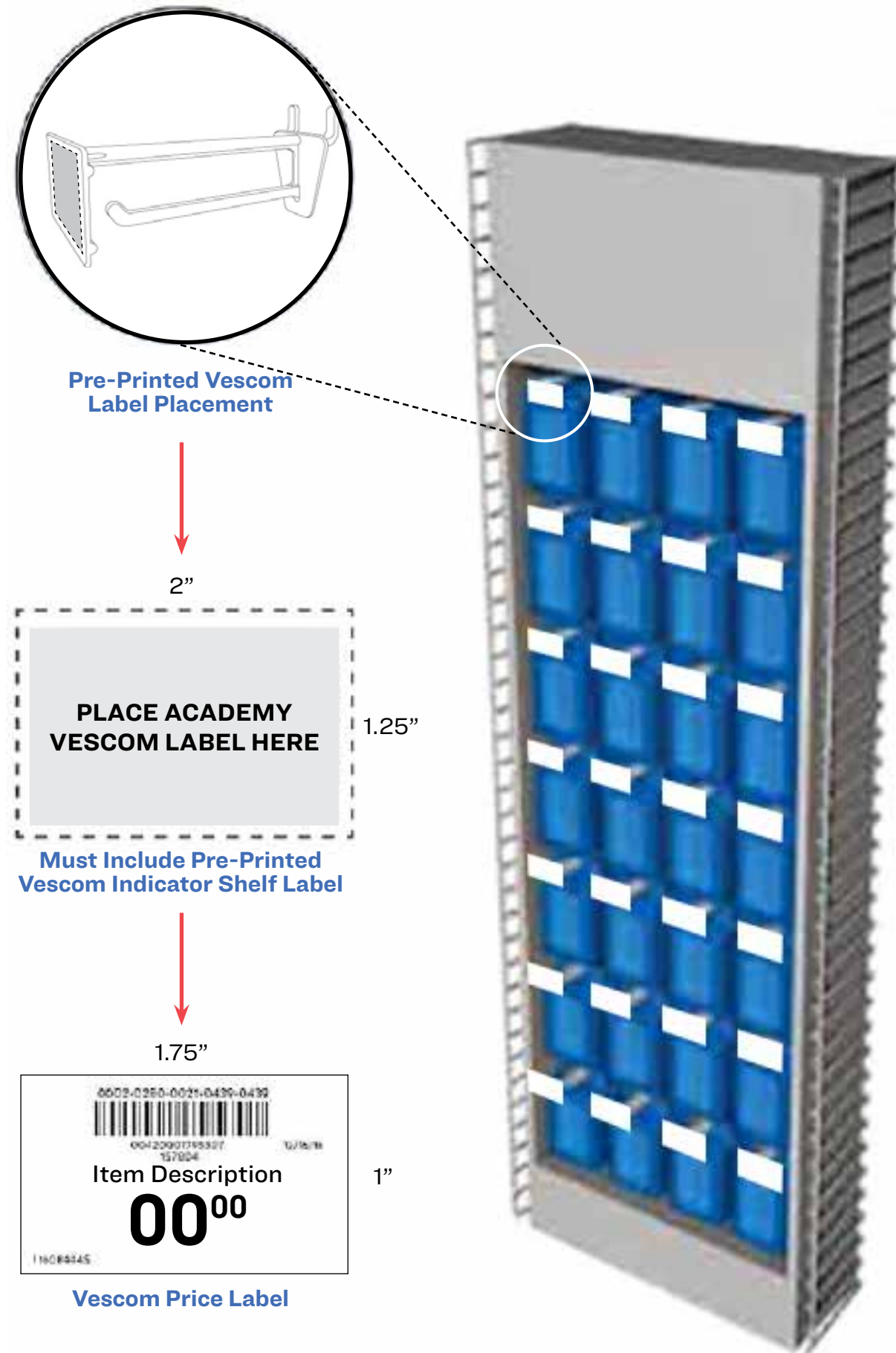

HARDWARE & SAFETY

SIDEKICK DISPLAY HARDWARE

- Sidekicks must be designed to be hung inside a standard sidekick wire frame or Skat Wall section. Hanging hardware must be sent inside the sidekick shipper in order for store associates to hang sidekick safely and securely.

SAFETY CONSIDERATIONS

- Sidekicks must securely hold the product in place during shipping and at store level. To ensure structural integrity, each display must be tested fully loaded with merchandise.

S-CLIP HARDWARE

- Must be included with all sidekick.
- Several different types of clips are available. Weight of the sidekick loaded with merchandise must be considered when ordering clips.
- Partner with Academy visual specialist for approval on hanging clips to confirm they will function properly.
- It is important to design a sidekick display with the s-clips in the proper location so that when it is hung it fits within the sidekick wire frame.
- Do not use zip ties to hang sidekick displays.
- **Structural sample must be delivered to the corporate office and allow 3 months for final approval before mass production begins.**

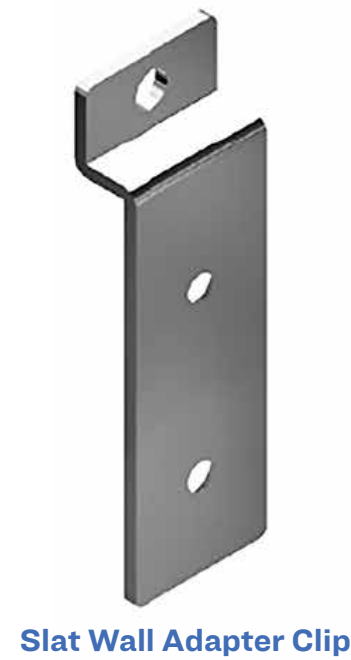

Clips into Magwall or Slat Wall Sidekick

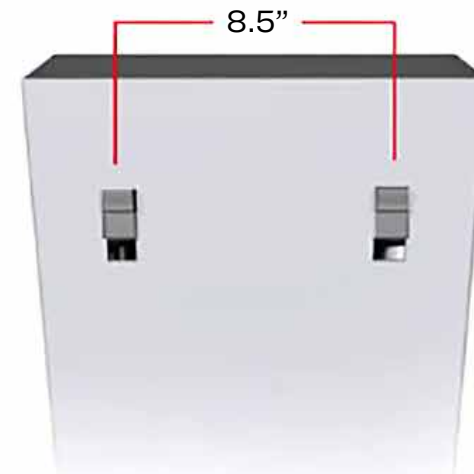
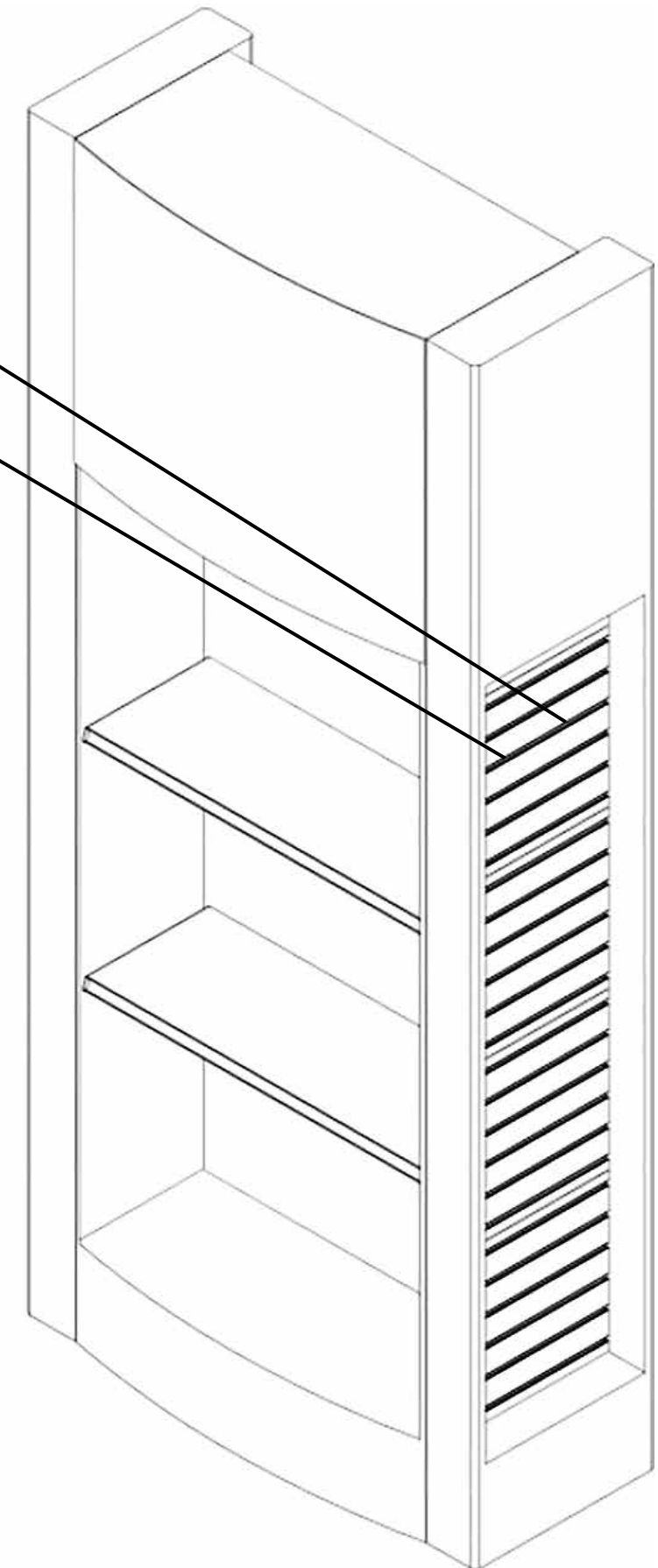
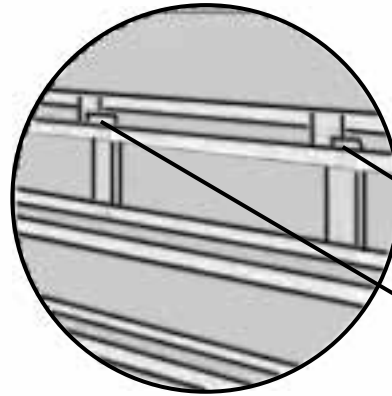

Proper Skat Wall Adapter Location

The above hardware shown can be sourced from siffron.com or kinter.com.

SHOW THE VALUE

THERE ARE 3 WAYS TO SHOW THE VALUE TO CUSTOMER WITH PDQ DISPLAYS - EDUCATION, INSPIRATION AND DEMONSTRATION

A display provides an in-store marketing opportunity for additional sales and product education. The customer's experience with a PDQ display should be considered when selecting the form of engagement. When creating a display, there may be some crossover in these 3 areas. This guide should serve as a framework to help develop each display for optimal performance.

1. EDUCATION

2. INSPIRATION

3. DEMONSTRATION

4. EDUCATIONAL RECOMMENDATIONS:

- Include relevant product claims.
- Link to mobile or digital information
- Highlight ratings and reviews

EDUCATION MESSAGING CONSIDERATIONS:

- PDQ displays should fulfill a relevant customer need by communicating a benefit
- A single marketing message communicates the benefit clearly as a call to action
- Education single marketing messages should be informative of the product features that deliver on the benefit
- Supporting copy plays off the marketing message, communicating the value.
- Reasons to believe communicate product claims, features or benefits that would further convince the customer to buy.
- All messaging should be as succinct as possible, communicating clearly and quickly to customers
- Note: all product claims included on the displays must be accurate, and the supplier must be able to substantiate those claims.



SHOW THE VALUE

PALLET DISPLAY BAD EDUCATION EXAMPLE

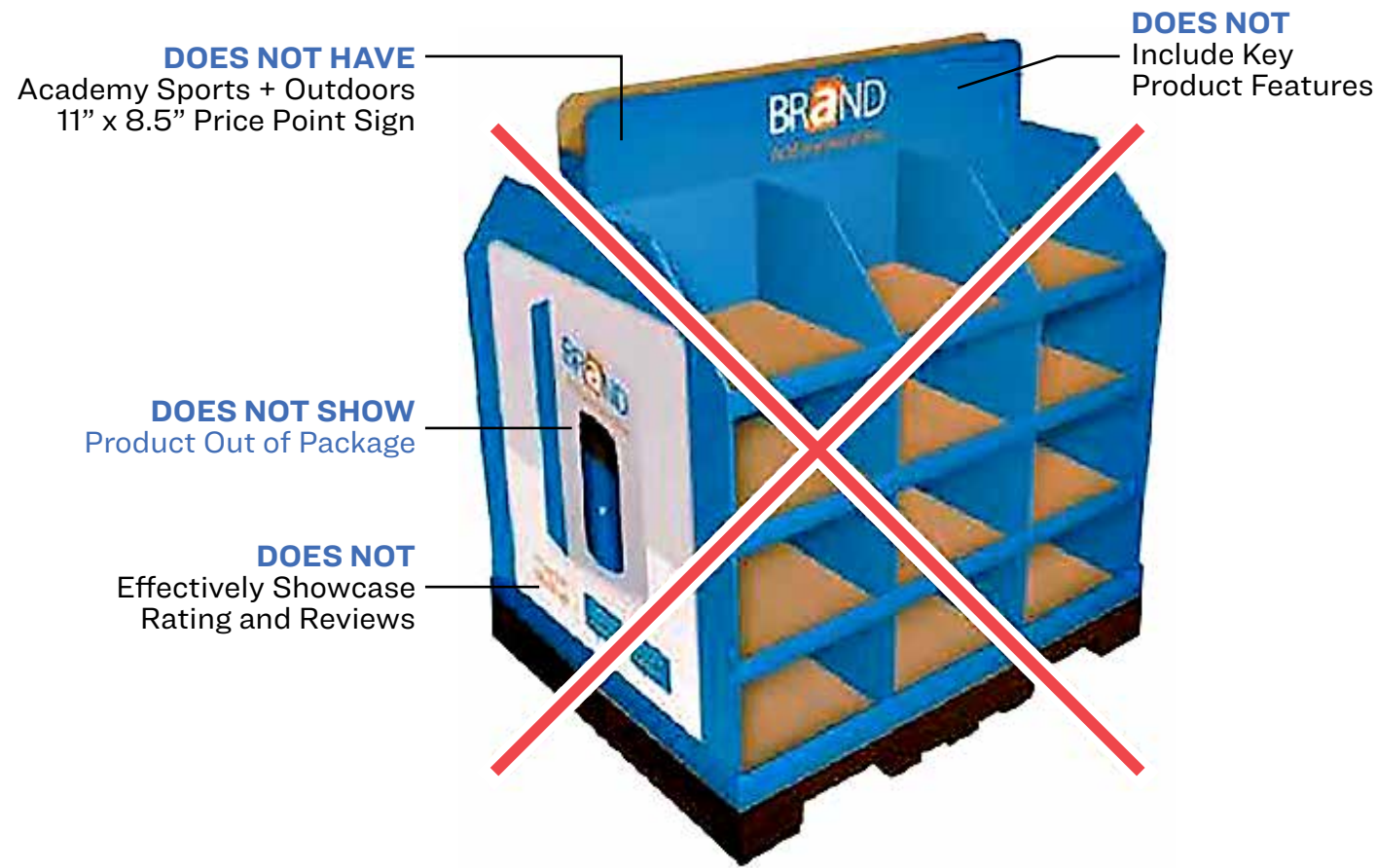

PALLET DISPLAY GOOD EDUCATION EXAMPLE



TRAY DISPLAY BAD EDUCATION EXAMPLE



TRAY DISPLAY GOOD EDUCATION EXAMPLE



CREATIVE COMMUNICATIONS

SINGLE-MINDED MARKETING MESSAGE

- Marketing message should be placed in the most prominent area of the display.
- All copy should have a high contrast from background to ensure legibility.
- Should be legible from 5'-10', copy should be approximately 1.5"-5" Tall. (Actual size will vary based on available graphic space)
- Supporting copy should be legible from 3'-5', copy should be approximately .75"-2" Tall (actual size will vary based on the available graphic space)

PRODUCT PHOTOGRAPHY

- High quality - 300 dpi
- In use or in environment.
- Show key product benefits.
- Does not show packaging.

KEY SELLING FEATURES

- PDQ should feature max 3 Key Selling Features
- Should be legible from 3', copy should be approximately .05"-1" Tall. (Actual size will vary based on the available graphic space)

LOGOS

- Logos should be a supporting element to the overall design.



GENERAL CRITERIA

A. DISPLAY HEIGHT (SETUP IN-STORE/LINE OF SIGHT)

- Maximum display height is 45" including pallet.
- Maximum overall height with sign header is 59".

B. PALLET

- Black Plastic pallets are required for Academy Sports + Outdoors
- iGPS pallets are an approved plastic option
- Should a display require a wood pallet it must be on a grade A hardwood, painted black.
- Corrugated pallets are not allowed for in-store PDQ's.
- CHEP, iGPS, and PECO are approved pallet poolers.
- Completed PDQs must be secured to pallets with stretch or shrink film, and carton labeling ensuring the film overlaps the pallet edges to prevent shifting and reduce the risk of damage during transit. GS1-128 labels and ASNs are required for all shipments per normal requirements.

C. DISTRIBUTION (SHIPPING) HEIGHT & WEIGHT

- Maximum distribution height is 50" including pallet unless pre-approved by Visual Merchandise Presentation.
- Maximum weight 2500 lbs.

D. OVER-HANG/UNDER-HANG

- Pallet over-hang is not allowed
- Pallet under-hang must not exceed 1".

E. DISPLAY SHIPPING FILLERS AND PRODUCT STOPS

- Shipping fillers should be utilized for product containment and to add support when displays are in transit.
- Product stops are required for using during shipment to secure product to hooks and prevent damage.

F. SHIPPING SHROUD AND TOP CAP

- Proper shipping shrouds and top caps protect displays and products during transit. A do not stack label must be applied.
- Secure PDQ to pallet to help prevent tipping during transit.
- The standard delivery side-up label must be applied to the outside.

G. CORNER POSTS

- Corner posts must be used to ensure strength during shipping. Corner posts can rest on top of pallet or extend all the way to the floor.
- A do not stack label must be applied.

H. NO STACK CONES

- Use No Stack Cones to protect PDQ from being crushed during shipment

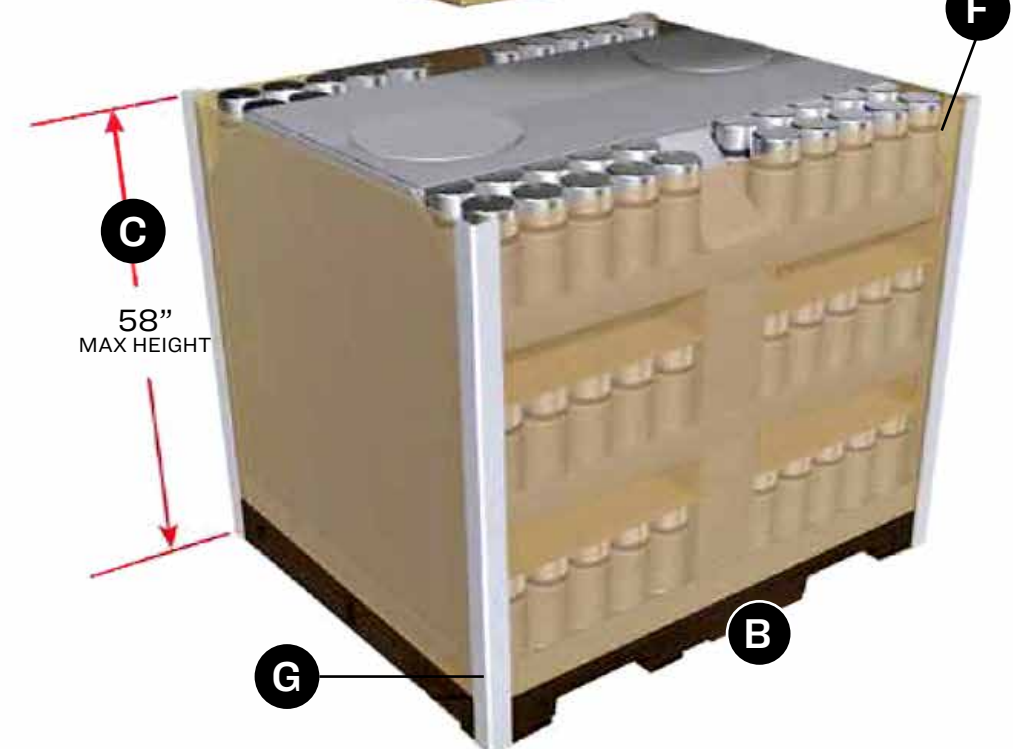

NO STACK CONE
Use No Stack Cones to protect pallets during shipment



PALLET SELECTION

PLASTIC PALLETS:

- Black plastic pallets are required for Academy Sports + Outdoors
- iGPS pallets are an approved plastic option

WOOD PALLETS, PAINTED BLACK:

- Some display programs may require a wood pallet. In the event that wood is needed the pallet must be painted black this will hide the imperfections and improve the appearance of the display.
- Should a display require a wood pallet it must be on a grade A hardwood, painted black.
- No broken or cracked components
- No bent or misshapen boards
- Wood must not be soft or brittle, as this compromises structural strength
- Free of pest and any signs of mold

FULL BLACK PLASTIC PALLET

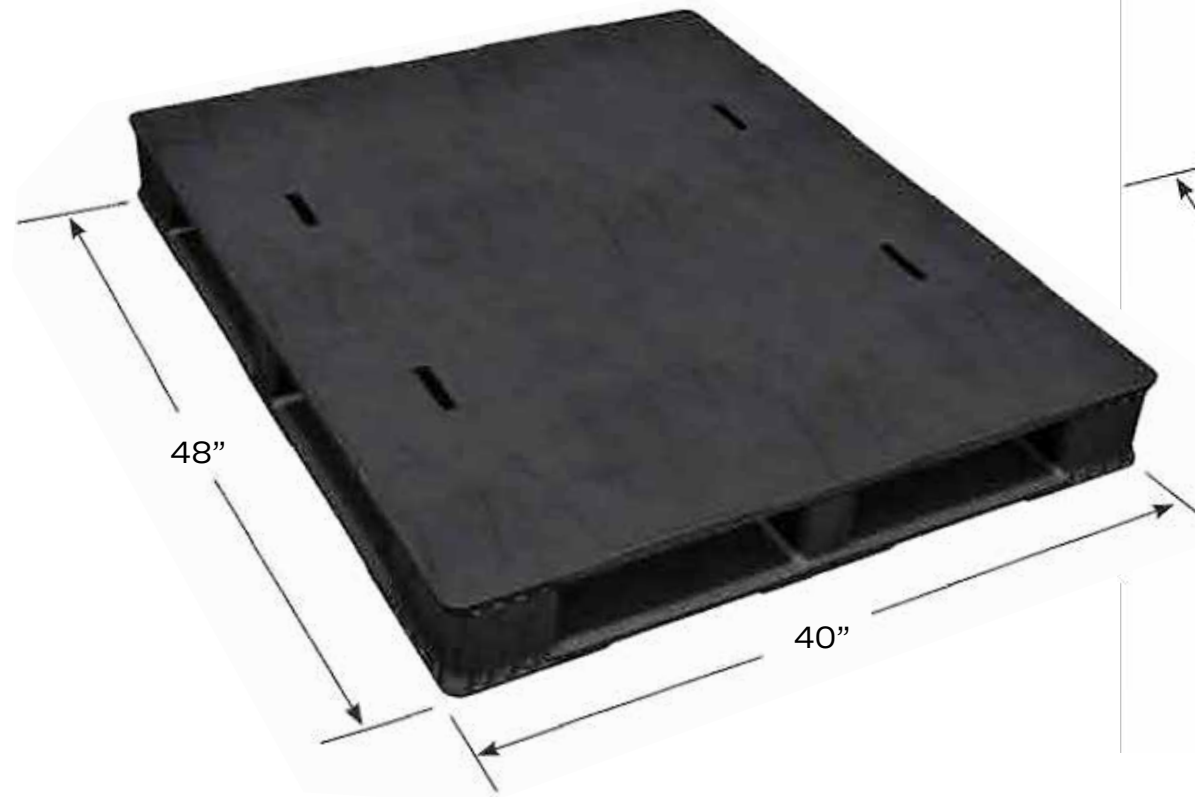

FULL WOOD PALLET - PAINTED BLACK



HALF BLACK PLASTIC PALLET



HALF WOOD PALLET - PAINTED BLACK



WEIGHT & HEIGHT

LIGHT WEIGHT PALLET:

- Individual pallets weighing under 750 lbs.
- The bottom layer of the pallet must be capable of supporting an additional 1500 lbs without comprising the integrity of the item or packaging (crushing, bending or tearing the merchandise or packaging) throughout the entire supply chain process.

HEAVY WEIGHT PALLET:

- Individual pallet weighing over 750 lbs
- The bottom layer of the pallet should be capable of supporting an additional 2500 lbs without compromising the integrity of the item or packaging throughout the entire supply chain process.
- Individual pallet load weight should not exceed 2500 lbs.
- All of product should not exceed a total of 2500 lbs, including the standard pallet weight.

COMPRESSION, SHOCK AND VIBRATION

- Freight shipment will likely face forklifts, conveyor belts and multiple transport vehicles along its way to its final destination, so in addition to weight and height specifications, proper packaging also helps cushion goods to withstand ordinary care in handling and to ensure that the product arrives to the stores in excellent condition.

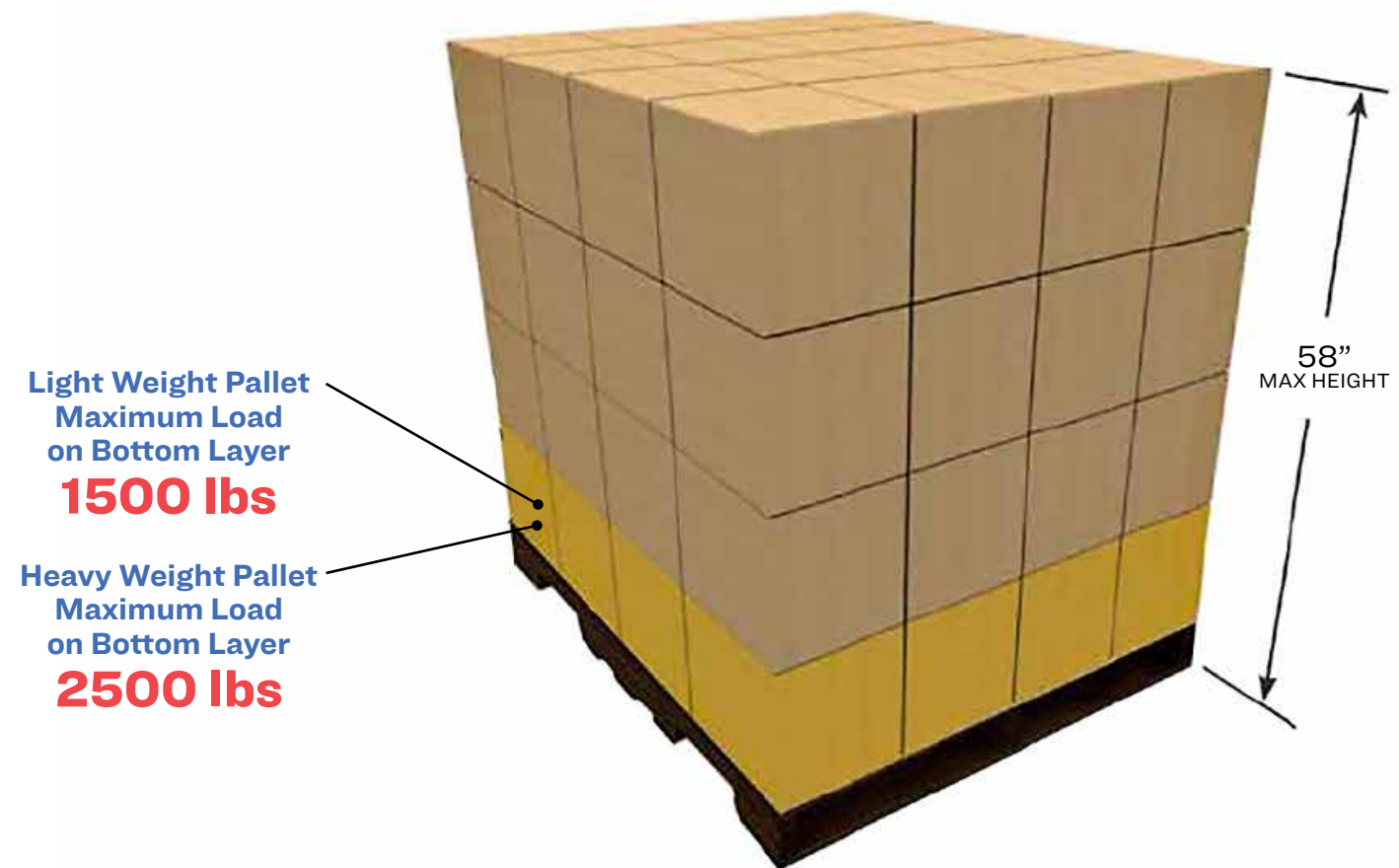

PRODUCT STAKING/OVER & UNDER-HANG

The orientation of cartons in your palletized freight shipments can have a big impact on the integrity of your shipments.

COLUMN STACK
Loads for palletized freight. In most cases column stacking increases the top-to-bottom compression strength for palletized shipments.



INTERLOCKING STACK
If the carton contents are rigid, such as pails of paint, interlocking cartons will result in increased stability. Stack corner-to-corner and edge-to-edge for better stacking strength.

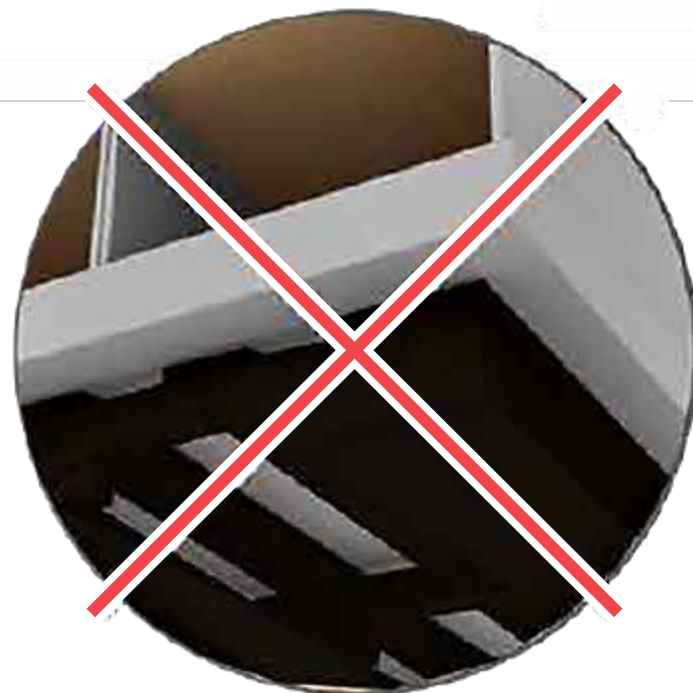

PALLET OVER-HANG
Over-hang on pallets with packaged products or displays is **NOT** allowed. It can reduce compression strength by as much as 32 percent, and it subjects packages and displays to tears, punctures and other impacts due to normal handling and sorting.

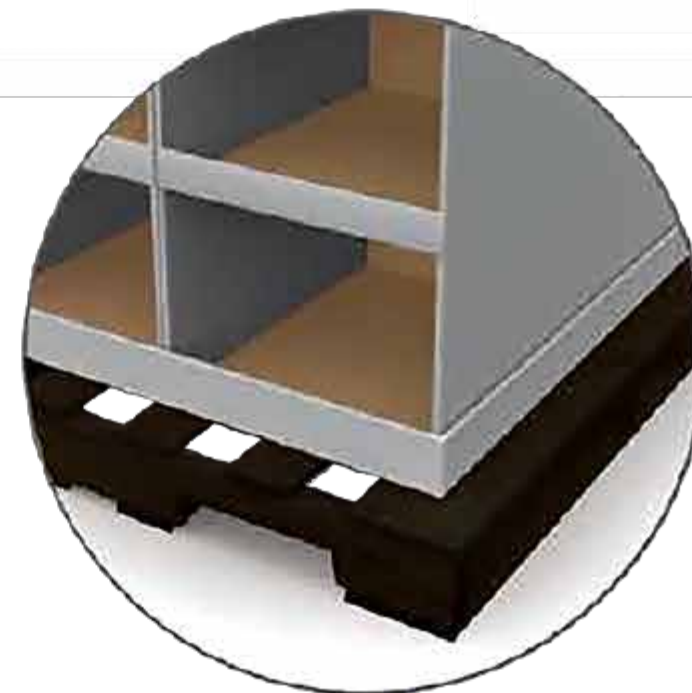

PALLET UNDER-HANG
Under-hang on pallets should **NOT** exceed 1". handling and sorting.

SHIPPING FILLERS

To minimize damage and to secure to products during shipment, shipping fillers are required. Without properly designed shipping fillers, products can shift and may not arrive to the store in good condition. For displays with peg hooks, peg hook shipping fillers or product stops may be secure to products.

ISTA shipping tests are recommended in order to ensure displays will withstand the rigors of shipment.

The examples shown below are common types of corrugated shipping fillers that are used to protect and secure products during shipment. The actual size and styles of shipping fillers will vary based on product needs.

U-Board Shipping Filler Keeps product from bouncing or shifting during shipping.



EXAMPLE ONLY

Void Shipping Filler Keeps product secure and fills the “void space” for added strength.



EXAMPLE ONLY